

USER MANUAL

Item: #13246 – Stand-Aid Lift

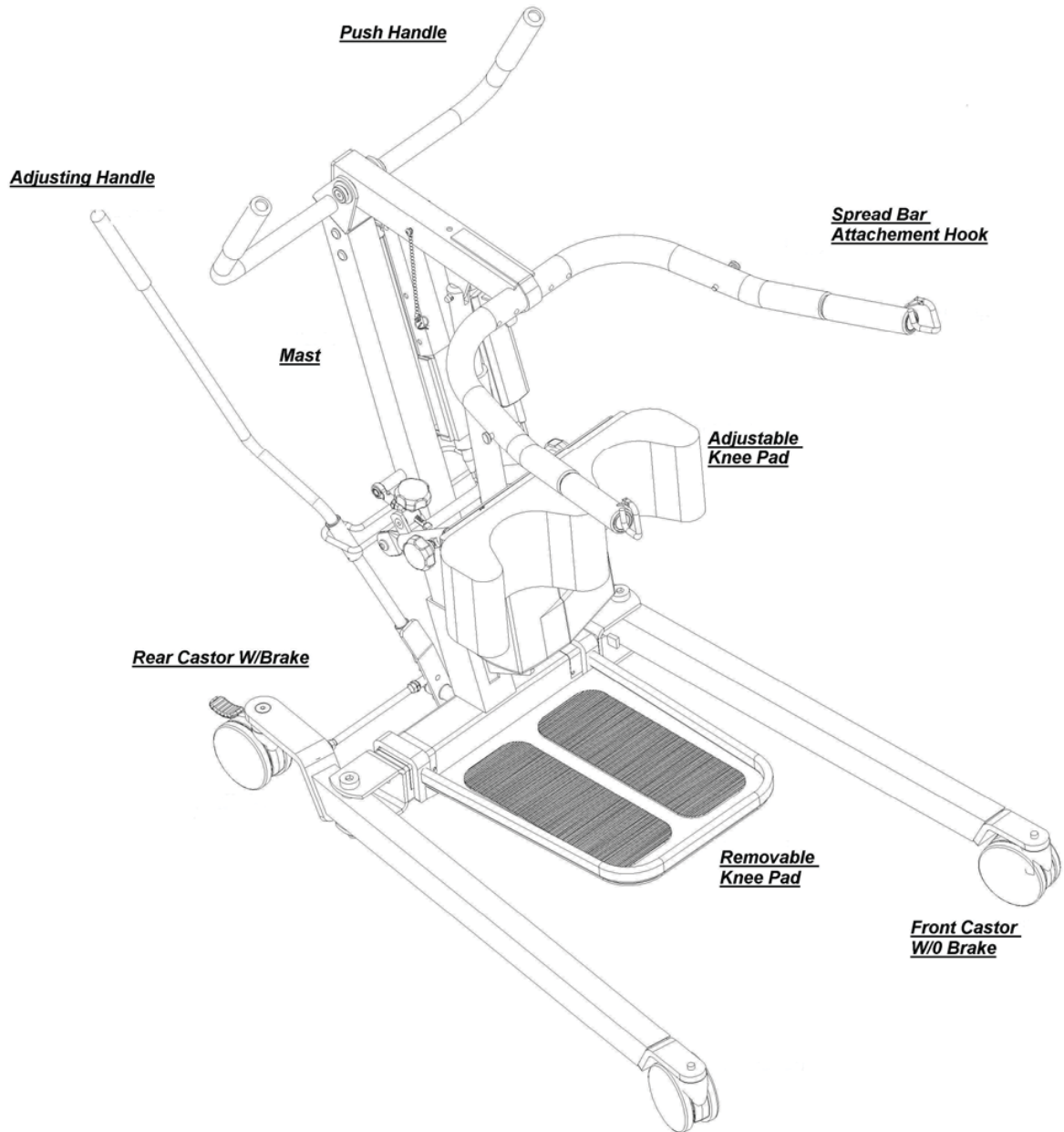

IMPORTANT SAFEGUARDS

- Your lift is for transferring patients only. Do not use the lift for any other purpose.
- “Stand-Aid Lift” is intended to be used for persons within the specified weight limit indicated for the lift. Do not attempt to lift more than the weight limit indicated.
- Before attempting to transfer, the user must be assessed by a qualified professional.
- The lift must be used by a caregiver with proper training to work with the person to be transferred.
- Only trained and qualified caregivers should transfer a person. Do not attempt to use the lift if you have not been properly trained to do so.
- Always be prepared before attempting to transfer a person.
- Do not use a sling that is not recommended for the lift.
- Do not store the lift in a shower, bath or other area with high humidity.
- Keep all components of the lift clean and dry and have electrical and mechanical safety.
- Always maneuver the lift with the handle provided.

ASSEMBLY INSTRUCTIONS

1. Remove all the parts from the carton and place on the floor, taking care to protect the finish from damage.

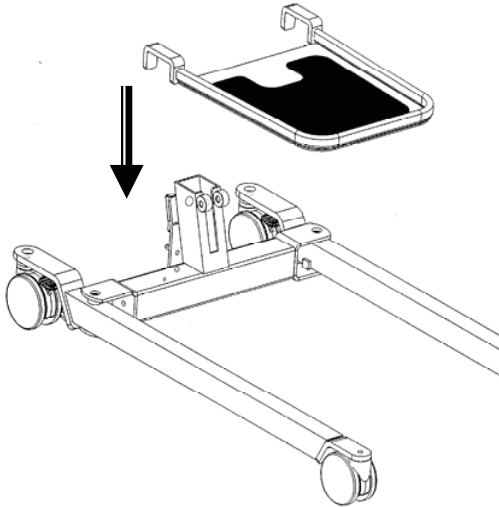

2. Place the chassis in a clear space and apply the rear brakes. Attach the “foot plate” to the base.

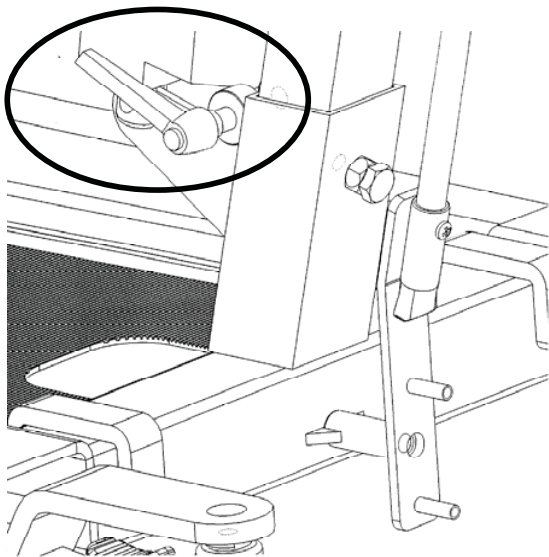
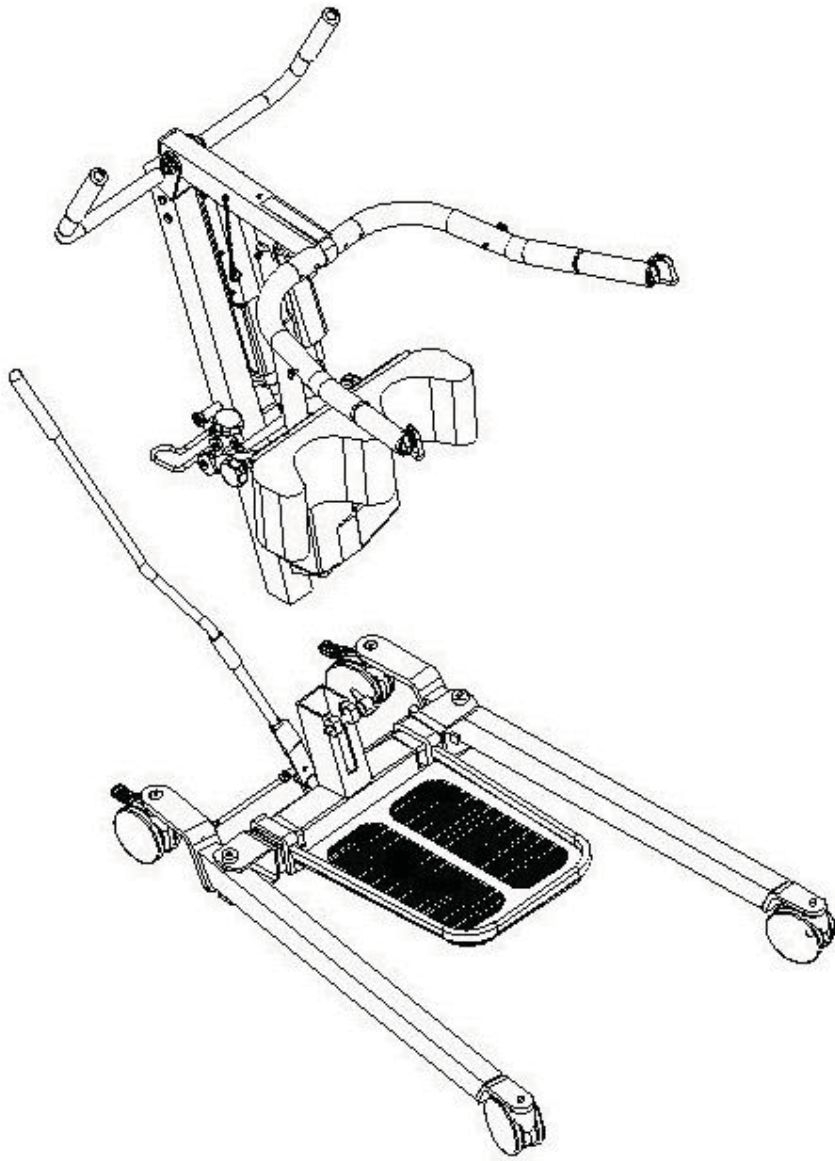

3. Fit the "mast" and "boom" assembly into the base socket. Tighten the mast assembly with the drive screw.



Tighten up screw



Assemble actuator bottom and top.



Insert the pin chain through actuator top.



Fit control box onto bracket (on mast).



Tight up control box.



Fit battery onto control box.



Plug the hand set in control box bottom at left

side.



Plug actuator in control box bottom at middle.

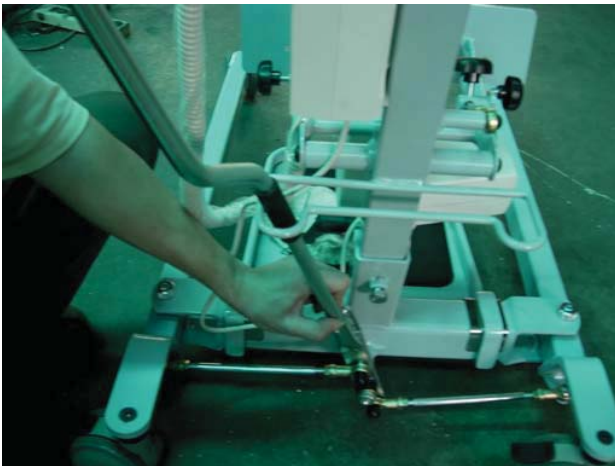

Fit the adjusting handle.

REMARKS:

Please always check the mast is fully locked into position.

I. How to Operate the Stand-Aid Lifter: (Weight Lifting Capacity: 180 kgs)

Important: Prior to first use, please make sure that the battery is being charged 24 hours in order to reach proper function and prolong the lifetime of battery.

1. Spread the base legs to the widest position before lifting.
2. Keep the patient centered between the base legs and have the patient face the attendant.
3. Be extremely cautious and use restraint straps for spastic or severely handicapped patients.
4. How to use Standard or Commode Slings:
 - a. For smooth and easy lifting, have the lift, chains, sling, commode or wheelchair in ready position.
 - b. With the patient in center of bed, roll on side away from the attendant.
 - c. Roll the patient to side toward the attendant and center the patient on sling. With base of lifter under bed, press the “↓” button on the control handset to lower the boom (#20).
 - d. Hook the hanging strips of sling with the hanging bar carefully. If a chain is used, make sure the “S” hooks are away from the patient.
 - e. Lock rear casters, lift the patient by pressing the “↑” button on the control handset.
 - f. Lift patient until his or her feet will swing easily off the bed keeping patient facing the attendant.
 - g. Unlock rear casters and transfer patient to and above commode or wheelchair. Lock brakes of both lifter and commode (or wheelchair).
 - h. Press the “↓” button on the control handset to gradually lower the patient.
 - i. During descent, assist patient to attain correct sitting posture.
 - j. For transferring to wheelchair, when patient is seated, push down on boom to slacken hanging strips of sling. Patient can remain seated in sling.
 - k. For commode use, adjust clothing before moving lift to straddle commode. Keep hanging strips taut and make sure patient is in a comfortable position.

Trouble Shooting (Linak LA34 System)

<i>Normal Symptom</i>	<i>Possible Cause</i>	<i>Action</i>
Power indicator does not light up.	<ul style="list-style-type: none"> ◆ Not connected to mains ◆ The fuse has blown ◆ Control box defective 	<ul style="list-style-type: none"> ◆ Connect to mains ◆ Replace fuse, if the system is prepared for external fuse replacement, or send the system to repair ◆ Send control box to repair
Power indicator lights up But actuator does not run.	<ul style="list-style-type: none"> ◆ Actuator plug not pushed into control properly ◆ Actuator defective ◆ Control box defective 	<ul style="list-style-type: none"> ◆ Push actuator plug into control box properly ◆ Replace actuator ◆ Replace control box
Relays in control box are heard clicking.	<ul style="list-style-type: none"> ◆ Control box defective 	<ul style="list-style-type: none"> ◆ Send control box repair
Power indicator lights up but actuator does not run.	<ul style="list-style-type: none"> ◆ Control box defective ◆ Handset defective 	<ul style="list-style-type: none"> ◆ send handset repair
No relay noise is heard from control box.	<ul style="list-style-type: none"> ◆ Handset plug not insert properly ◆ Emergency stop engaged 	<ul style="list-style-type: none"> ◆ Check all cord connections ◆ Deactivate emergency stop

	◆ Charger plugged in	◆ Unplug charger
Control box completely dead on battery and no relay clicking is heard.	◆ Battery completely flat ◆ Battery defective	◆ Charge battery ◆ Replace battery
Control box okay apart from	◆ handset defective	◆ Send handset for repair
One direction on one channel	◆ Control box defective	◆ Send control box for repair

Warning and Caution!

1. Patient lifter is a Transfer Device that allows patient attendant to transfer patients from bed to wheelchair or commode...etc. It however should not be used to transport patients.
2. When lifting patient, make sure the base legs are in the most widely opened position and the rear caster brakes are engaged. Otherwise, the lifter may tilt over.
3. When battery power is 50% low, the controller will give "beep" warning. At this moment, you should charge the battery immediately. Please note that a lifted patient cannot be lowered down when battery is out of power.
4. Push the "Emergency" red button if the control unit system is out of control.
5. "QUICK RELEASE" system (push/pull) enables stepless retraction of the actuator under load (Mechanical emergency lowering). Refer to Picture A.

Picture A:

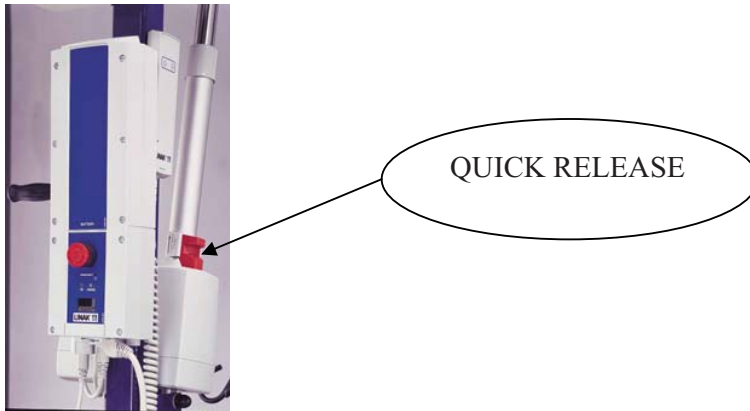

6. How to Charge: (please refer to Picture B)
 - a. With Jumbo Linak set (battery box, control box & actuator) assembled, insert the power cord plug in control box and the other end to a wall outlet.
 - b. Now, it is charging, the "Charge" light is on.
 - c. When the charging action is finished, the "Charge" light will be off automatically. (Usually, it is need to charge 4 hours from the 50% capacity to 100% capacity)
 - d. Remove the power supply cord.
 - e. Now, you can operate again.

PICTURE B:

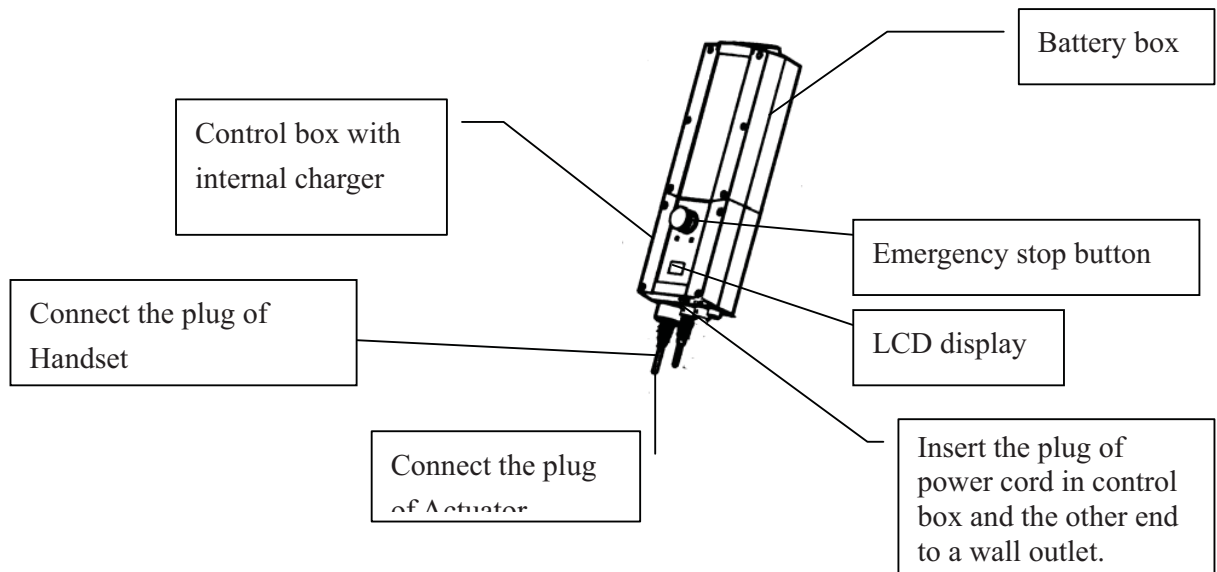

Maintenance:

It is extremely important that the lift be inspected before each use. The following items need to be checked:

- a. All nuts and bolts should be tight.
- b. The lifter should move freely with caster brakes off.
- c. Check the brakes on the rear casters for proper operation.
- d. Make sure base adjustment mechanism is operating easily.
- e. Double check to ensure the “U” bracket at the end of the boom and the “S” hook on the hanging bar are secured tightly.
- f. Work the Linak Actuator to ensure that the battery still has enough power. When battery is 50% below full capacity, it will give “beep” warning and need to re-charge immediately.
- g. Before initial use, place a drop of oil on the following areas.
 - (1) Where mast and boom connect, hanging bar hook, pump handle hinge, and caster axles,
 - (2) Where pump and boom attach,
 - (3) Lubricate as above every two to three months.

* We reserves the right to make technical changes without notice

Manufactured For:

Drive Medical Design & Manufacturing

99 Seaview Boulevard

Port Washington, NY 11050

Phone: 516-998-4600

Fax: 516-998-4601

www.drivemedical.com