

# Commercial Trus<T>Lift Installation Instructions

The Commercial Trus<T>Lift is pre-assembled and tested in the factory before shipping. The lift is then disassembled into the components shown in Figure 1. **All fasteners required to assemble the lift are re-installed in their respective positions after disassembly, except for the Lower Mechanical Stops (5/8" X 3" Carriage Bolts) included with the small parts bag.**

Assembly of the Commercial unit is as follows:

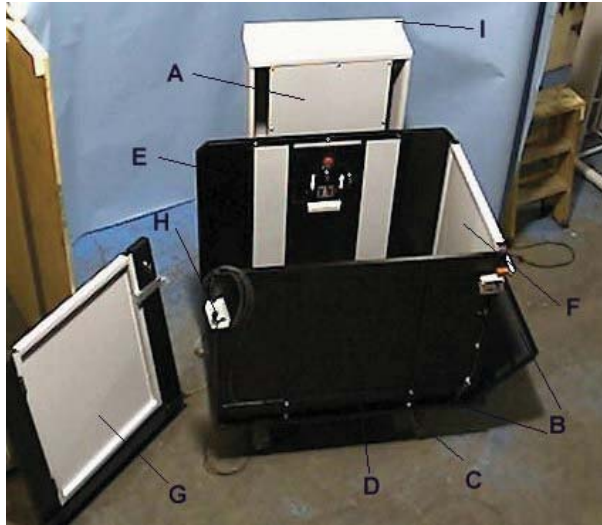

FIG. 1- PARTS INCLUDED WITH A STRAIGHT COMMERCIAL UNIT

## Straight or Adjacent Access Unit

- Carefully unpackage the Commercial Trus<T>Lift components, confirm the following parts as shown in Fig. 1 are included:
  - Trus<T>Lift Tower Part A
  - Carriage with Toe Plate Part B
  - Base Frame Part C
  - Solid Handrail Part D
  - Control Wall Extension Part E
  - Carriage Gate Part F
  - Upper Gate Part G
  - Lower Remote Call Station Part H
  - Tower Mounting Angle Part I

*Adjacent Unit will also include a corner post (not shown)*

- Install the base frame, tower and carriage according to the *Trus<T>Lift Installation Manual* Pages 1-1 to 2-3. In order to operate the lift without field wiring completed:
  - Use two 12" insulated jumper wires and bypass from #1 to #2 **and** #4 to #5 for down movement
  - For up movement jump from #1 to #2 only

***Use extreme caution when running the unit down as the lower limit switch is bypassed and the drive nuts could possibly run out of the guide channel***
- Plug the Under Deck Safety Limits into the Inside Junction Box as shown in Fig. 2.
- **From this point forward in order to run the unit without the field wiring completed, only bypass #1 to #2 on the terminal strip (do not hardwire the jumper wire in place, only bypass when movement is required)**



FIG. 2- PLUGGING IN UNDER DECK SAFETY LIMITS



FIG. 3- REMOVE FRONT PANEL

- Remove the front panel from the Trus<T>Lift Unit as shown in Fig. 3.



FIG. 4- INSTALLING LOWER MECHANICAL STOPS

- Insert the (2X) 5/8"X3" Carriage Bolts and 5/8" Jam Nuts into the Lower Mechanical Stop brackets on the underside of the guide frame as shown in Fig. 4. Thread the bolts into the Mechanical stops about 1/2", they will be adjusted and jammed into place towards the end on the installation.



FIG. 5A- INSTALLING CONTROL WALL EXTENSION

- Mount the Control Wall Extension to the Guide Frame as shown in Fig. 5A/5B.
- Fasteners- (6X) 10/32 X 1/2" Flathead screws with (6X) Chrome Finishing Washers



FIG. 5B- FASTENING CONTROL WALL EXTENSION TO GUIDE FRAME



FIG. 6A- LOWER THE HANDRAIL INTO PLACE

- For a Straight Access Unit Mount the Solid Handrail to the Carriage as shown in Fig. 6A/6B
- Fasteners- (4X) 5/16 X 1 3/4" Bolts, (8X) 5/16 Washers, (4X) 5/16 Locknuts)
  - For an Adjacent Access Unit Mount the Solid Handrail to the Carriage as shown in Fig. 7A/7B, the safety pan must be lowered to access the mounting holes. After mounting the Solid Handrail attach it to the Control Wall Extension using small 1" Angle, remount safety pan to finish
- Fasteners- (3X) 3/8 X 1 1/4" Bolts, (3X) 3/8" Locknuts, (2X) 10/32 X 1/2" Screws



FIG. 6B- BOLT HANDRAIL TO CARRIAGE



FIG. 7A- LOWER SAFTEY PAN TO ACCESS BOLT HOLES



FIG. 7B- BOLT HANDRAIL TO CARRIAGE



FIG. 8- MOUNTING GATE TO CONTROL WALL EXTENSION

- Mount the Carriage Gate to the Control Wall Extension as shown in Fig. 8.
- Fasteners- (8X) 12/24 X 1/2" Flathead Screws

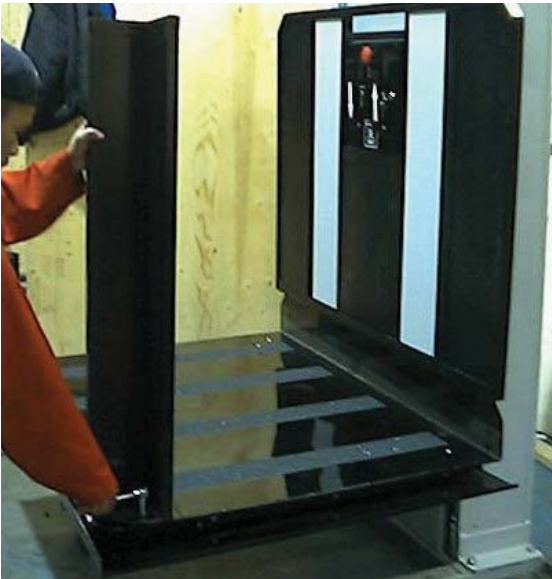

FIG. 9- MOUNT CORNER POST FOR ADJACENT UNIT

- On Adjacent Units mount the corner post as shown in Fig. 9. Square it to Carriage Gate, if necessary shim with washers provided



FIG. 10- RUN CABLE UNDER TOE PLATE

- Run Interlock cable under the toe plate as in Fig. 10



FIG. 11- MOUNT INTERLOCK TO SOLID HANDRAIL

- Mount the Carriage Gate Interlock to the Solid Hand Rail for a Straight Unit and to the Corner Post for an Adjacent Unit as shown in Fig. 11.
- Fasteners- (2X) 10/32 X 1½” Screws



FIG. 12- ADJUST INTERLOCK KEY TAB IF NECESSARY

- Adjustment of the Interlock Key Tab may be necessary to allow proper alignment, loosen the (2X) 10/32 X ½” screws mounting it to the Aluminum Gate Tab and adjust as necessary as shown in Fig. 12



FIG. 13- ADJUSTING SPRING LOADED HINGE

- Adjust the Spring Loaded Hinge on the Carriage Gate as shown in Fig. 13, this allows the gate to self-close against the Interlock.
- Use a 5/32” Allen Key to release the tension on the loaded pin (turn clock wise)
- Remove the set pin from the hinge
- Increase tension (clock wise) or decrease tension (counter clock wise) and reinsert the set pin



FIG. 14- FASTEN CABLE TO SAFETY PLATE USING STRAPS

- Fasten the Carriage Gate Interlock Cable to the Safety Plate under the Toe Plate using the plastic Nylon Tie Straps provided as shown in Fig. 14



FIG. 15- DRILL THROUGH BOTH ANGLE EDGES TO FASTEN GATE TO THRESHOLD

- Mount the Upper Gate to the threshold at the upper landing as in Fig.15
  - Drill through the 5" X 5" Angle on the Upper Gate frame at suitable locations to provide adequate mounting holes for the angle, lag bolt or screw into place. **OR** Use a Polyurethane Adhesive to mount the threshold to the upper landing



FIG. 16- USE ADHESIVE TO FASTEN GATE TO EXISTING STRUCTURE

- Use a Polyurethane Adhesive to mount the Upper Gate Post uprights to the existing structure as in Fig. 16

*When using the Polyurethane Adhesive adequate clamping and support must be in place until the adhesive sets properly (**NOTE CLAMP IN FIG. 16**)*



FIG. 17- MOUNT LOWER CALL STATION

- Mount the Lower Remote Call Station in a suitable location as in Fig. 17
- Run electrical conduit from the call station to the Outside Junction Box as well as from the Upper Gate to the Outside Junction Box located on the bottom left side of the Trus<T>Lift tower
- Run the cables from the Call Station and Upper Gate through the conduit to the Outside Junction Box



FIG. 18- WIRING OUTSIDE JUNCTION BOX

- The wires from the call station and Upper Gate and/or Interlocks are labeled with numbers that match the labels on the wires in the Outside Junction Box. The Outside Junction box is located at the bottom left side of the tower. Use the wire marrets provided to make the connections as in Fig. 18. (*Unplug unit from power source before wiring*)
- Plug the unit in or hard wire it to an outlet providing 120 V.A.C. and 15 AMP protection

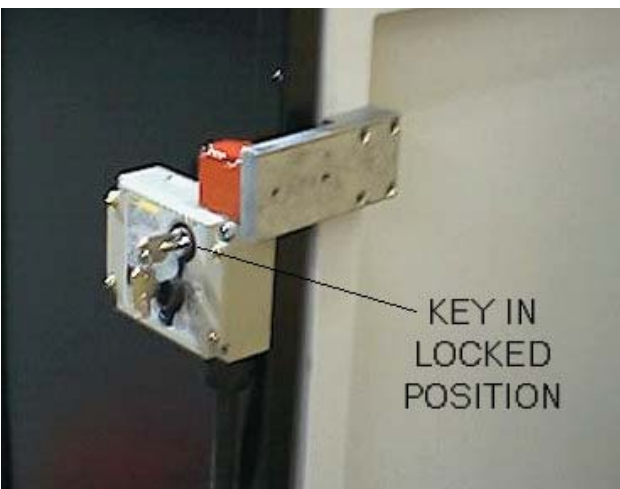

FIG. 19- INTERLOCKS MUST BE LOCKED FOR LIFT TO RUN PROPERLY

- The Interlocks (both on the carriage and the upper gate) should be in the "Locked" Position as in Fig. 19 for the Trus<T>Lift unit to run.

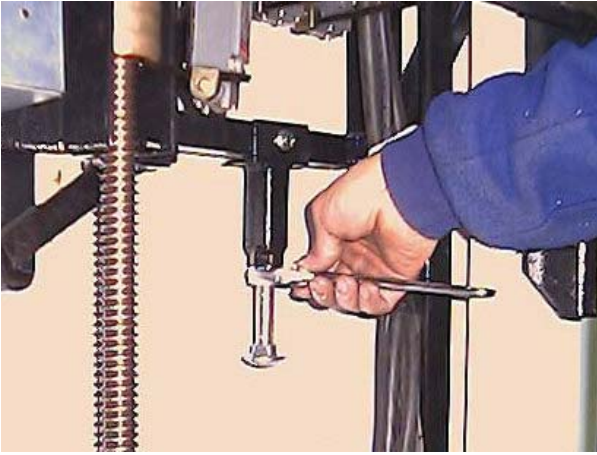

FIG. 20- TIGHTEN LOWER MECHANICAL STOPS

- Run the lift up and adjust the Lower Mechanical Stops so the lift stops at the bottom by breaking the Lower Limit circuit as apposed to activating the Safety Plate circuit, once adjusted use the jam nuts to lock them into place as in Fig. 20.



FIG. 21- MOUNT TOWER TO EXISTING STRUCTURE

- The electrical limit switch stop for the upper landing is controlled by adjusting the Upper Limit Adjusting Bracket as described in the *Trus<T>Lift Installation Manual on page 2-7 Fig.17*

- Mount the tower to the existing structure as in Fig. 21. Instructions are included with the tower-mounting angle

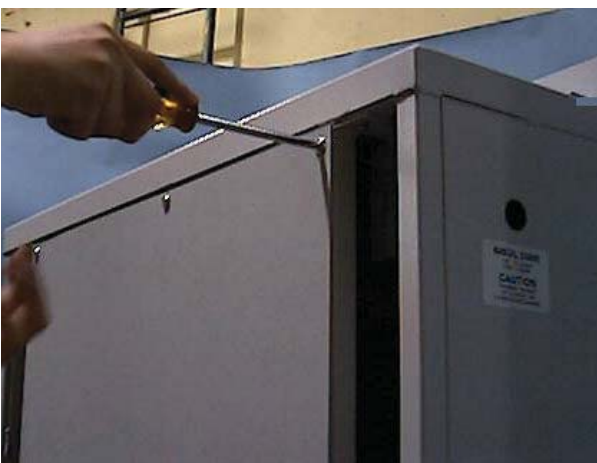
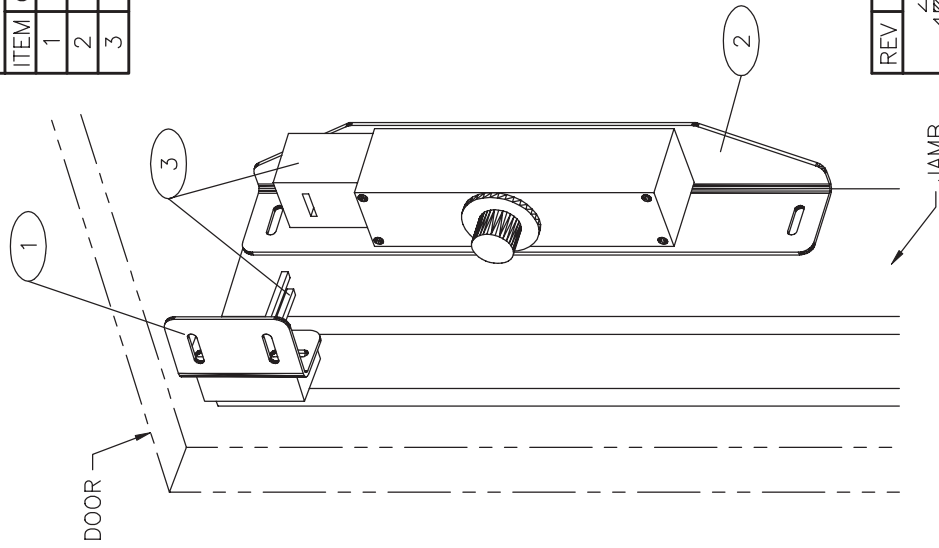

FIG. 22- INSTALL FRONT PANEL

- Reinstall the Front panel into the Trus<T>Lift Unit as in Fig. 22

PARTS LIST

ITEM	QTY	PART NUMBER	DESCRIPTION
1	1	FFBTC117	RES. DOOR TAB BRACKET - STI LOCK
2	1	FFBTC114	STI LOCK MOUNTING ANGLE
3	1		GATE STI INTERLOCK & TAB



VIEW #2 LOOKING FROM  
OUTSIDE OF SHAFT

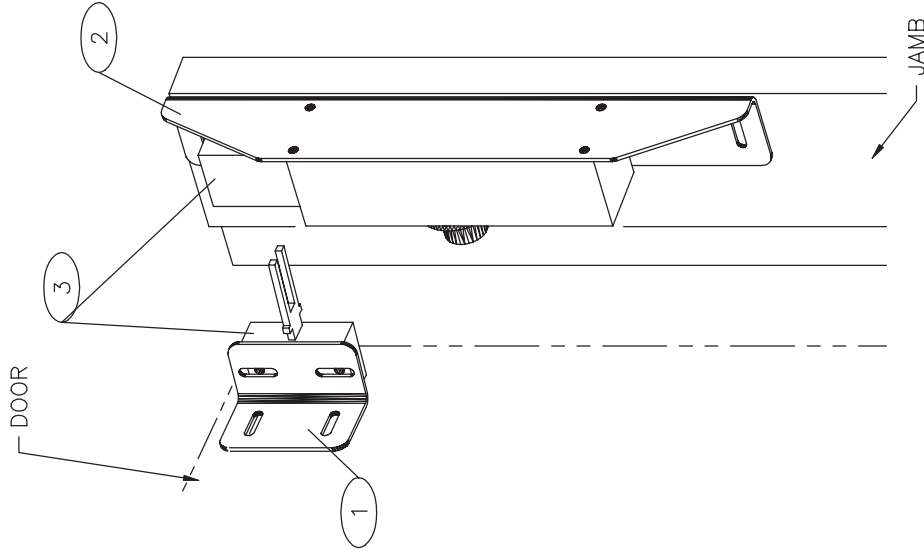

VIEW #1 LOOKING FROM  
INSIDE OF SHAFT

REV BY DATE DESCRIPTION

 **RAM MANUFACTURING LTD.**

DWN. BY:  
B. HANNAH

TRUS-T-LIFT

RESIDENTIAL DOOR INTERLOCK  
ASSEMBLY - STI INTERLOCK

SCALE: N.T.S.

DATE: 13/12 / 04

DRAWING No.  
AFBTC116

REV